

Pompa per Vuoto
Le pompe per vuoto industriali
ANELLO 25E

Pompa per Vuoto ad Anello Liquido, Serie Economica con Alto Livello di Performance



Anello 25 E è una pompa per vuoto ad anello liquido della Serie Eco.

Il grado di vuoto finale di questa pompa ad anello liquido è di 33 mbar. E' una pompa semplice da installare, progettata compatta e fusa con la tecnica della colata a cera persa. Anello 25 E è una pompa particolarmente silenziosa e dalla facile manutenzione. Disponibile standard con statore in ghisa e rotore in inox, tutta in AISI 304 o tutta in AISI 316.

Anello 25E it's Eco Series Liquid Ring Vacuum Pump.

The ultimate vacuum of Anello 25 E is 33 mbar. It's a pump easy to install, with a saving space design, product with the technique of lost wax casting. Anello 25 E it's a very low-noise pump. Available in std item (iron cast-SS), in SS AISI 304 or SS AISI 316.



Contattaci

Hai delle domande o Vuoi una quotazione?
t. 02.48.82.614



Appointment

One of our technician can study with you the solutions for your application.
info@tbf.it

Pompa per Vuoto

Le pompe per vuoto industriali

ANELLO 25E

Anello 25 E – Ingombri

Anello 25 E – Dimensions

Anello 25 E – Componenti

Anello 25 E – Components

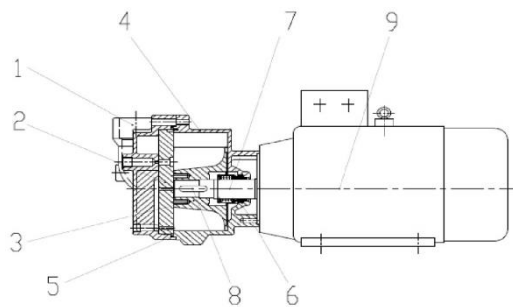
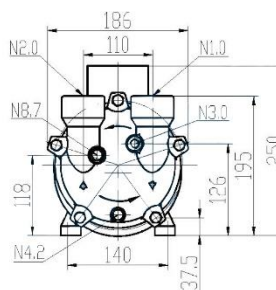
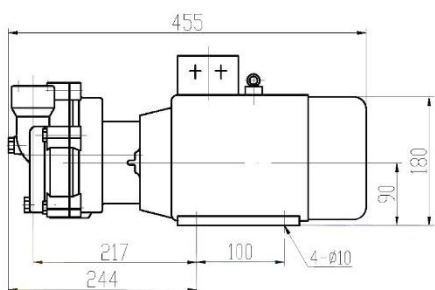

N1.0	N2.0	N3.0	N4.2	N8.7
Gas Inlet	Exhaust	Water Inlet	Drain	Cavitation Protection
G 1"	G 1"	G 3/8"	G 1/4"	G 3/8"

1	Pump cover	2	Separate plate
3	Impeller	4	Pump casing
5	O-ring	6	Mechanic al seal
7	Shaft	8	Flat key
9	Motor		

Anello 25 E – Informazioni Tecniche

Anello 25 E – Technical Informations

Motor Type	Voltage	Rotation Speed		Power		Absorption		Air Flow		Weight	
		50 Hz	60 Hz	50 Hz	60 Hz	50 Hz	60 Hz	50 Hz	60 Hz	50 Hz	60 Hz
3 phase	400V	2840 rpm	3410 rpm	0,81 kW	1,5 kW	1,8 A	3,1 A	27 m ³ /h	32 m ³ /h	15 kg	20 kg

Ultimate Vacuum	Operating Liquid	Operating Liquid Temperature	Discharge Pressure	Trasmission
33 mbar	Water	4 - 30°C	0,02 MPa	Coupling

Anello 25 E – Consumo Acqua

Anello 25 E – Water Consumption

< 200 mbar	200 – 600 mbar	> 600 mbar
2,5 l/min	1,7 – 2,5 l/min	0,8 – 1,7 l/min

Anello 25 E – Curve Portata

Anello 25 E – Flow Diagram

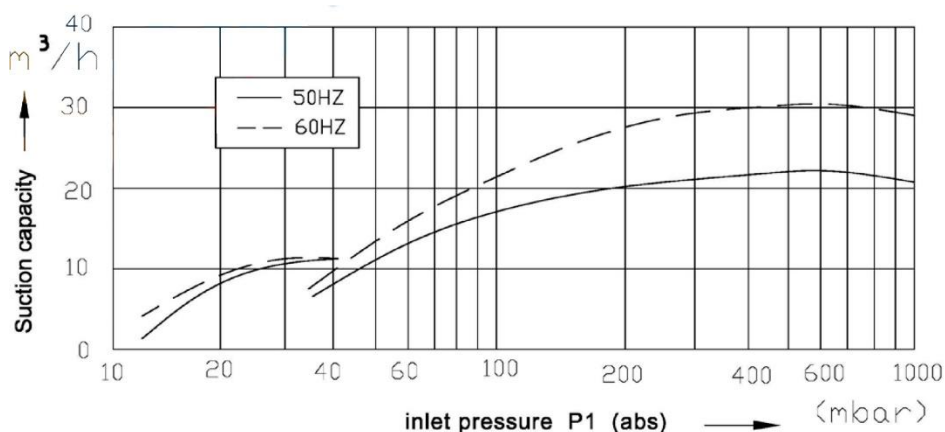

Contattaci

Hai delle domande o Vuoi una quotazione?
t. 02.48.82.614

Appointment

One of our technician can study with you the solutions for your application.
info@tbf.it