



*POMPE PER VUOTO*

GRIPPERS

# VENTOSE A SOFFIETTO SERIE M

Ventose da 50 a 85,99

Bellows Cups from 50 to 85,99



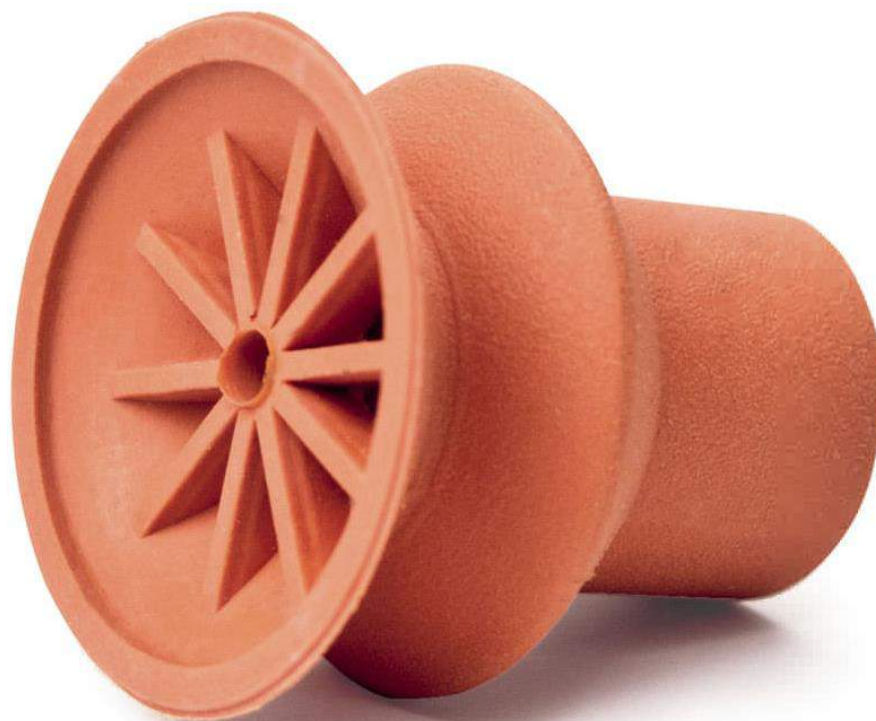

Oltre alle pompe per vuoto è nata l'esigenza di soddisfare le richieste dei clienti di fornitura di ventose.

Siamo in contatto con molti produttori così da ricambiare le ventose già da Voi utilizzate. Abbiamo anche una ns. linea di ventose, serie M, economiche e di elevate performance. Contattaci per dei preventivi o per un contatto con un nostro tecnico.

More than Vacuum Pumps, Customers ask more and more frequently to TBF many different type of grippers. TBF are in contact to many brand and manufacturer so we can offer the some grippers you already use (1:1). But now we also have our new line of grippers, M series, cheap and with high performance and durability. Contact us for any further information or for a quote.

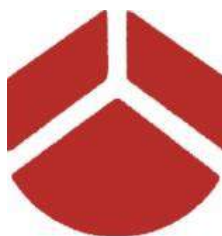



Disponiamo di un gran numero di materiali tra cui NBR, Silicone, Poliuretano, Para Naturale e molti altri. Oltre alla forma della ventosa è importante scegliere il materiale migliore per la Vs applicazione.

We have more and more materials for our grippers, for example: NBR, Silicone Rubber, Polyrethan, Natural Rubber and each others. It's very important choose the best material for your application as the shape.





| 210.050.039._ |                       |                       |
|---------------|-----------------------|-----------------------|
|               | <b>Materialcode</b>   |                       |
|               | 02 Silikon            |                       |
|               | <b>Halter Fitting</b> | <b>Gewinde Thread</b> |
|               | 130.256               | M8 AG                 |
|               |                       |                       |
| 10mm          | 12.8g                 |                       |

| 210.050.057._ |   |                       |
|---------------|---|-----------------------|
|               | <b>Materialcode</b>                         |                       |
|               | 04 CR<br>09 HNBR<br>03 NR<br>05 Polyurethan |                       |
|               | <b>Halter Fitting</b>                       | <b>Gewinde Thread</b> |
|               | 130.012                                     | 1/8" AG               |
|               |   |                       |
| 10mm          | 22.3g                                       |                       |

| 210.050.115._ |   |                       |
|---------------|---|-----------------------|
|               | <b>Materialcode</b>   |                       |
|               | 04 CR<br>01 NBR<br>03 NR<br>05 Polyurethan  |                       |
|               | <b>Halter Fitting</b>   | <b>Gewinde Thread</b> |
|               | 130.137 1/8" IG<br>130.177 M10 AG<br>130.190 1/4" AG<br>130.192 1/4" IG<br>130.244 M5 AG<br>130.252 1/8" IG<br>130.294 1/4" AG<br>130.296 3/8" AG |                       |
|               |   |                       |
| 11mm          | 20.0g   |                       |

| 210.050.116._ |                       |                       |
|---------------|-----------------------|-----------------------|
|               | <b>Materialcode</b>   |                       |
|               | 02 Silikon            |                       |
|               | <b>Halter Fitting</b> | <b>Gewinde Thread</b> |
|               |                       |                       |
|               |                       |                       |
| 10mm          | 19.0g                 |                       |



210.050.118.\_

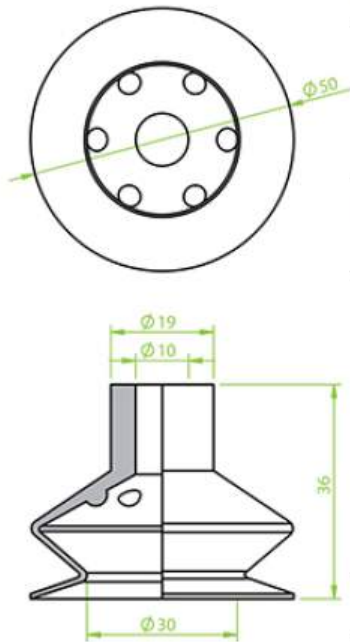

Materialcode

03 NR

Halter  
Fitting

130.132  
130.614

Gewinde  
Thread

1/8" AG  
1/4" AG



10mm

20.0g

210.050.804.\_

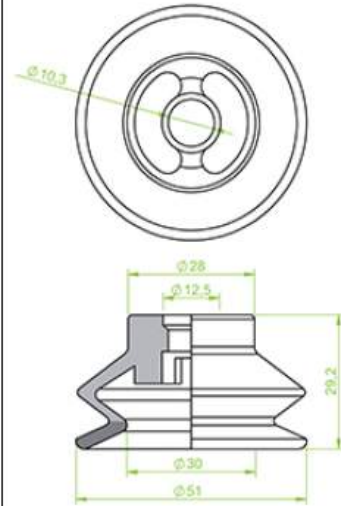

Materialcode

05 Polyurethan  
20 TPU

Halter  
Fitting

130.252  
130.294  
130.296

Gewinde  
Thread

1/8" IG  
1/4" AG  
3/8" AG



14.4mm

20.5g

213.050.012.\_

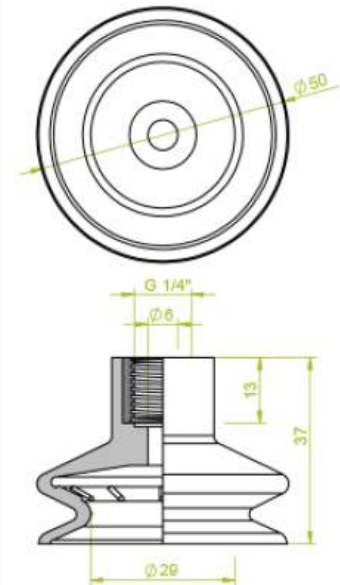

Materialcode

03 NR  
02 Silikon

Halter  
Fitting

Gewinde  
Thread



12mm

21.0g

220.050.038.\_

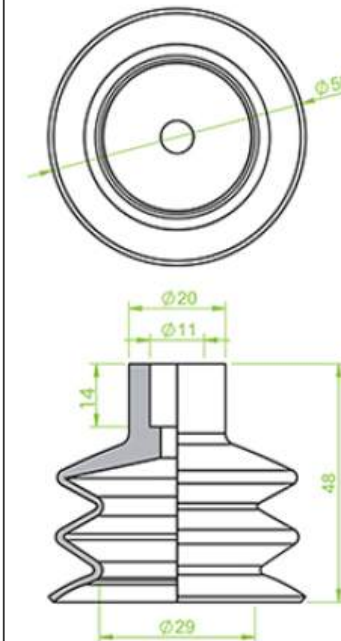

Materialcode

03 NR  
02 Silikon

Halter  
Fitting

130.098  
130.609

Gewinde  
Thread

1/4" IG  
1/4" AG



18mm

20.0g



| 220.050.082._                 |                               |
|-------------------------------|-------------------------------|
|                               | <b>Materialcode</b>           |
|                               | 03 NR<br>02 Silikon           |
| <b>Halter Fitting</b>         | <b>Gewinde Thread</b>         |
| 130.097<br>130.098<br>130.609 | 1/4" AG<br>1/4" IG<br>1/4" AG |
|                               |                               |
| 8mm                           | 30.0g                         |

| 220.050.083._         |                       |
|-----------------------|-----------------------|
|                       | <b>Materialcode</b>   |
|                       | V Vinyl               |
| <b>Halter Fitting</b> | <b>Gewinde Thread</b> |
| 130.609               | 1/4" AG               |
|                       |                       |
| mm                    | 0.0g                  |

| 220.050.803._         |                       |
|-----------------------|-----------------------|
|                       | <b>Materialcode</b>   |
|                       | 20 TPU                |
| <b>Halter Fitting</b> | <b>Gewinde Thread</b> |
| 130.252<br>130.294    | 1/8" IG<br>1/4" AG    |
|                       |                       |
| 20mm                  | 20.0g                 |

| 223.050.001._         |                       |
|-----------------------|-----------------------|
|                       | <b>Materialcode</b>   |
|                       | 03 NR<br>02 Silikon   |
| <b>Halter Fitting</b> | <b>Gewinde Thread</b> |
|                       |                       |
|                       |                       |
| 18mm                  | 30.0g                 |



| 223.050.009._  |   |                |                |  |
|----------------|---|----------------|----------------|--|
|                | <b>Materialcode</b><br>03 NR<br>02 Silikon  |                |                |  |
|                | <table border="1"> <thead> <tr> <th>Halter Fitting</th> <th>Gewinde Thread</th> </tr> </thead> <tbody> <tr> <td></td> <td></td> </tr> </tbody> </table> | Halter Fitting | Gewinde Thread |  |
| Halter Fitting | Gewinde Thread  |                |                |  |
|                |   |                |                |  |
|                | <table border="1"> <tbody> <tr> <td>8mm</td> <td>30.0g</td> </tr> </tbody> </table>   | 8mm            | 30.0g          |  |
| 8mm            | 30.0g   |                |                |  |

| 240.050.005._  |   |                |                |         |         |         |         |         |
|----------------|---|----------------|----------------|---------|---------|---------|---------|---------|
|                | <b>Materialcode</b><br>04 CR<br>02 Silikon  |                |                |         |         |         |         |         |
|                | <table border="1"> <thead> <tr> <th>Halter Fitting</th> <th>Gewinde Thread</th> </tr> </thead> <tbody> <tr> <td>130.252</td> <td>1/8" IG</td> </tr> <tr> <td>130.294</td> <td>1/4" AG</td> </tr> <tr> <td>130.296</td> <td>3/8" AG</td> </tr> </tbody> </table> | Halter Fitting | Gewinde Thread | 130.252 | 1/8" IG | 130.294 | 1/4" AG | 130.296 |
| Halter Fitting | Gewinde Thread  |                |                |         |         |         |         |         |
| 130.252        | 1/8" IG   |                |                |         |         |         |         |         |
| 130.294        | 1/4" AG   |                |                |         |         |         |         |         |
| 130.296        | 3/8" AG   |                |                |         |         |         |         |         |
|                | <table border="1"> <tbody> <tr> <td>25mm</td> <td>25.0g</td> </tr> </tbody> </table>  | 25mm           | 25.0g          |         |         |         |         |         |
| 25mm           | 25.0g   |                |                |         |         |         |         |         |

| 210.052.032._  |  |                |                |         |         |         |         |         |         |         |
|----------------|--|----------------|----------------|---------|---------|---------|---------|---------|---------|---------|
|                | <b>Materialcode</b><br>04 CR<br>07 FKM<br>09 HNBR<br>03 NR   |                |                |         |         |         |         |         |         |         |
|                | <table border="1"> <thead> <tr> <th>Halter Fitting</th> <th>Gewinde Thread</th> </tr> </thead> <tbody> <tr> <td>130.137</td> <td>1/8" IG</td> </tr> <tr> <td>130.252</td> <td>1/8" IG</td> </tr> <tr> <td>130.294</td> <td>1/4" AG</td> </tr> <tr> <td>130.296</td> <td>3/8" AG</td> </tr> </tbody> </table> | Halter Fitting | Gewinde Thread | 130.137 | 1/8" IG | 130.252 | 1/8" IG | 130.294 | 1/4" AG | 130.296 |
| Halter Fitting | Gewinde Thread   |                |                |         |         |         |         |         |         |         |
| 130.137        | 1/8" IG  |                |                |         |         |         |         |         |         |         |
| 130.252        | 1/8" IG  |                |                |         |         |         |         |         |         |         |
| 130.294        | 1/4" AG  |                |                |         |         |         |         |         |         |         |
| 130.296        | 3/8" AG  |                |                |         |         |         |         |         |         |         |
|                | <table border="1"> <tbody> <tr> <td>12mm</td> <td>22.0g</td> </tr> </tbody> </table>   | 12mm           | 22.0g          |         |         |         |         |         |         |         |
| 12mm           | 22.0g  |                |                |         |         |         |         |         |         |         |

| 210.052.125._  |   |                |                |         |         |         |         |         |
|----------------|---|----------------|----------------|---------|---------|---------|---------|---------|
|                | <b>Materialcode</b><br>V Vinyl  |                |                |         |         |         |         |         |
|                | <table border="1"> <thead> <tr> <th>Halter Fitting</th> <th>Gewinde Thread</th> </tr> </thead> <tbody> <tr> <td>130.132</td> <td>1/8" AG</td> </tr> <tr> <td>130.190</td> <td>1/4" AG</td> </tr> <tr> <td>130.192</td> <td>1/4" IG</td> </tr> </tbody> </table> | Halter Fitting | Gewinde Thread | 130.132 | 1/8" AG | 130.190 | 1/4" AG | 130.192 |
| Halter Fitting | Gewinde Thread  |                |                |         |         |         |         |         |
| 130.132        | 1/8" AG   |                |                |         |         |         |         |         |
| 130.190        | 1/4" AG   |                |                |         |         |         |         |         |
| 130.192        | 1/4" IG   |                |                |         |         |         |         |         |
|                | <table border="1"> <tbody> <tr> <td>mm</td> <td>0.0g</td> </tr> </tbody> </table>   | mm             | 0.0g           |         |         |         |         |         |
| mm             | 0.0g  |                |                |         |         |         |         |         |



| 210.052.129._ |  |                     |                |
|---------------|--|---------------------|----------------|
|               |  | <b>Materialcode</b> |                |
|               |  | 02 Silikon          |                |
|               |  | <b>Halter</b>       | <b>Gewinde</b> |
|               |  | Fitting             | Thread         |
|               |  |                     |                |
|               |  | mm                  | 0.0g           |

| 211.052.005._ |  |                                     |                |
|---------------|--|-------------------------------------|----------------|
|               |  | <b>Materialcode</b>                 |                |
|               |  | 04 CR<br>07 FKM<br>09 HNBR<br>03 NR |                |
|               |  | <b>Halter</b>                       | <b>Gewinde</b> |
|               |  | Fitting                             | Thread         |
|               |  |                                     |                |
|               |  | 12mm                                | 54.0g          |

| 220.052.085._ |  |                     |                |
|---------------|--|---------------------|----------------|
|               |  | <b>Materialcode</b> |                |
|               |  | 02 Silikon          |                |
|               |  | <b>Halter</b>       | <b>Gewinde</b> |
|               |  | Fitting             | Thread         |
|               |  |                     |                |
|               |  | 12mm                | 25.0g          |

| 210.053.017._ |  |   |                |
|---------------|--|---|----------------|
|               |  | <b>Materialcode</b>                         |                |
|               |  | 04 CR<br>09 HNBR<br>03 NR<br>05 Polyurethan |                |
|               |  | <b>Halter</b>                               | <b>Gewinde</b> |
|               |  | Fitting                                     | Thread         |
|               |  |   |                |
|               |  | 11mm  | 19.0g          |





| 214.055.015._         |                              |
|-----------------------|------------------------------|
|                       | <b>Materialcode</b>          |
|                       | 05 Polyurethan<br>02 Silikon |
| <b>Halter Fitting</b> | <b>Gewinde Thread</b>        |
|                       |                              |
|                       |                              |
| 20mm                  | 47.0g                        |

| 210.056.127._         |                       |
|-----------------------|-----------------------|
|                       | <b>Materialcode</b>   |
|                       | 03 NR<br>02 Silikon   |
| <b>Halter Fitting</b> | <b>Gewinde Thread</b> |
| 130.049<br>130.609    | 1/4" AG<br>1/4" AG    |
|                       |                       |
| 16mm                  | 16.0g                 |

| 240.058.025._         |                       |
|-----------------------|-----------------------|
|                       | <b>Materialcode</b>   |
|                       | V Vinyl               |
| <b>Halter Fitting</b> | <b>Gewinde Thread</b> |
|                       |                       |
|                       |                       |
| mm                    | 0.0g                  |

| 210.060.023._                                       |   |
|---|---|
|   | <b>Materialcode</b>                                 |
|   | 03 NR<br>02 Silikon<br>12 verstärktes Silikon       |
| <b>Halter Fitting</b>                               | <b>Gewinde Thread</b>                               |
| 130.092<br>130.093<br>130.099<br>130.248<br>130.249 | 1/8" IG<br>1/8" AG<br>1/4" AG<br>1/4" IG<br>1/4" AG |
|   |   |
| 15mm  | 33.0g   |



| 210.060.130._  |  |                |                |         |         |         |
|----------------|--|----------------|----------------|---------|---------|---------|
|                | <b>Materialcode</b><br>02 Silikon  |                |                |         |         |         |
|                | <table border="1"> <thead> <tr> <th>Halter Fitting</th> <th>Gewinde Thread</th> </tr> </thead> <tbody> <tr> <td>130.281</td> <td>1/4" AG</td> </tr> <tr> <td>130.282</td> <td>1/4" IG</td> </tr> </tbody> </table> | Halter Fitting | Gewinde Thread | 130.281 | 1/4" AG | 130.282 |
| Halter Fitting | Gewinde Thread   |                |                |         |         |         |
| 130.281        | 1/4" AG  |                |                |         |         |         |
| 130.282        | 1/4" IG  |                |                |         |         |         |
|                |  |                |                |         |         |         |
| 12mm           | 40.0g  |                |                |         |         |         |

| 211.060.015._  |   |                |                |  |
|----------------|---|----------------|----------------|--|
|                | <b>Materialcode</b><br>02 Silikon   |                |                |  |
|                | <table border="1"> <thead> <tr> <th>Halter Fitting</th> <th>Gewinde Thread</th> </tr> </thead> <tbody> <tr> <td></td> <td></td> </tr> </tbody> </table> | Halter Fitting | Gewinde Thread |  |
| Halter Fitting | Gewinde Thread  |                |                |  |
|                |   |                |                |  |
|                |   |                |                |  |
| 11mm           | 45.0g   |                |                |  |

| 220.060.026._  |   |                |                |         |         |         |         |         |         |         |         |         |
|----------------|---|----------------|----------------|---------|---------|---------|---------|---------|---------|---------|---------|---------|
|                | <b>Materialcode</b><br>06 EPDM<br>03 NR<br>05 Polyurethan<br>02 Silikon   |                |                |         |         |         |         |         |         |         |         |         |
|                | <table border="1"> <thead> <tr> <th>Halter Fitting</th> <th>Gewinde Thread</th> </tr> </thead> <tbody> <tr> <td>130.092</td> <td>1/8" IG</td> </tr> <tr> <td>130.093</td> <td>1/8" AG</td> </tr> <tr> <td>130.099</td> <td>1/4" AG</td> </tr> <tr> <td>130.248</td> <td>1/4" IG</td> </tr> <tr> <td>130.249</td> <td>1/4" AG</td> </tr> </tbody> </table> | Halter Fitting | Gewinde Thread | 130.092 | 1/8" IG | 130.093 | 1/8" AG | 130.099 | 1/4" AG | 130.248 | 1/4" IG | 130.249 |
| Halter Fitting | Gewinde Thread  |                |                |         |         |         |         |         |         |         |         |         |
| 130.092        | 1/8" IG   |                |                |         |         |         |         |         |         |         |         |         |
| 130.093        | 1/8" AG   |                |                |         |         |         |         |         |         |         |         |         |
| 130.099        | 1/4" AG   |                |                |         |         |         |         |         |         |         |         |         |
| 130.248        | 1/4" IG   |                |                |         |         |         |         |         |         |         |         |         |
| 130.249        | 1/4" AG   |                |                |         |         |         |         |         |         |         |         |         |
|                |   |                |                |         |         |         |         |         |         |         |         |         |
| 24mm           | 60.0g   |                |                |         |         |         |         |         |         |         |         |         |

| 220.060.037._  |  |                |                |         |         |         |
|----------------|--|----------------|----------------|---------|---------|---------|
|                | <b>Materialcode</b><br>03 NR<br>02 Silikon   |                |                |         |         |         |
|                | <table border="1"> <thead> <tr> <th>Halter Fitting</th> <th>Gewinde Thread</th> </tr> </thead> <tbody> <tr> <td>130.281</td> <td>1/4" AG</td> </tr> <tr> <td>130.282</td> <td>1/4" IG</td> </tr> </tbody> </table> | Halter Fitting | Gewinde Thread | 130.281 | 1/4" AG | 130.282 |
| Halter Fitting | Gewinde Thread   |                |                |         |         |         |
| 130.281        | 1/4" AG  |                |                |         |         |         |
| 130.282        | 1/4" IG  |                |                |         |         |         |
|                |  |                |                |         |         |         |
| 25mm           | 40.0g  |                |                |         |         |         |



| 220.060.087._         |                       |
|-----------------------|-----------------------|
|                       | <b>Materialcode</b>   |
|                       | 03 NR                 |
| <b>Halter Fitting</b> | <b>Gewinde Thread</b> |
|                       |                       |
| 25mm                  | 30.0g                 |

| 220.060.100._         |                       |
|-----------------------|-----------------------|
|                       | <b>Materialcode</b>   |
|                       | 01 NBR<br>02 Silikon  |
| <b>Halter Fitting</b> | <b>Gewinde Thread</b> |
| 130.248<br>130.249    | 1/4" IG<br>1/4" AG    |
|                       |                       |
| 35mm                  | 29.6g                 |

| 220.060.131._         |                       |
|-----------------------|-----------------------|
|                       | <b>Materialcode</b>   |
|                       | 02 Silikon            |
| <b>Halter Fitting</b> | <b>Gewinde Thread</b> |
|                       |                       |
| mm                    | 0.0g                  |

| 221.060.010._         |   |
|-----------------------|---|
|                       | <b>Materialcode</b>   |
|                       | 06 EPDM<br>05 Polyurethan<br>02 Silikon<br>12 verstärktes Silikon |
| <b>Halter Fitting</b> | <b>Gewinde Thread</b>   |
|                       |   |
| 24mm                  | 55.0g   |



| 220.062.035._  |  |                |                |         |         |         |         |         |         |         |
|----------------|--|----------------|----------------|---------|---------|---------|---------|---------|---------|---------|
|                | <b>Materialcode</b><br>04 CR<br>09 HNBR<br>03 NR<br>05 Polyurethan   |                |                |         |         |         |         |         |         |         |
|                | <table border="1"> <thead> <tr> <th>Halter Fitting</th> <th>Gewinde Thread</th> </tr> </thead> <tbody> <tr> <td>130.092</td> <td>1/8" IG</td> </tr> <tr> <td>130.093</td> <td>1/8" AG</td> </tr> <tr> <td>130.281</td> <td>1/4" AG</td> </tr> <tr> <td>130.282</td> <td>1/4" IG</td> </tr> </tbody> </table> | Halter Fitting | Gewinde Thread | 130.092 | 1/8" IG | 130.093 | 1/8" AG | 130.281 | 1/4" AG | 130.282 |
| Halter Fitting | Gewinde Thread   |                |                |         |         |         |         |         |         |         |
| 130.092        | 1/8" IG  |                |                |         |         |         |         |         |         |         |
| 130.093        | 1/8" AG  |                |                |         |         |         |         |         |         |         |
| 130.281        | 1/4" AG  |                |                |         |         |         |         |         |         |         |
| 130.282        | 1/4" IG  |                |                |         |         |         |         |         |         |         |
|                |  |                |                |         |         |         |         |         |         |         |
| 25mm           | 45.7g  |                |                |         |         |         |         |         |         |         |

| 222.062.009._  |   |                |                |         |
|----------------|---|----------------|----------------|---------|
|                | <b>Materialcode</b><br>02 Silikon<br>12 verstärktes Silikon   |                |                |         |
|                | <table border="1"> <thead> <tr> <th>Halter Fitting</th> <th>Gewinde Thread</th> </tr> </thead> <tbody> <tr> <td>130.281</td> <td>1/4" AG</td> </tr> </tbody> </table> | Halter Fitting | Gewinde Thread | 130.281 |
| Halter Fitting | Gewinde Thread  |                |                |         |
| 130.281        | 1/4" AG   |                |                |         |
|                |   |                |                |         |
| 25mm           | 60.0g   |                |                |         |

| 210.070.105._  |  |                |                |         |         |         |
|----------------|--|----------------|----------------|---------|---------|---------|
|                | <b>Materialcode</b><br>02 Silikon<br>V Vinyl   |                |                |         |         |         |
|                | <table border="1"> <thead> <tr> <th>Halter Fitting</th> <th>Gewinde Thread</th> </tr> </thead> <tbody> <tr> <td>130.145</td> <td>1/4" AG</td> </tr> <tr> <td>130.184</td> <td>1/4" AG</td> </tr> </tbody> </table> | Halter Fitting | Gewinde Thread | 130.145 | 1/4" AG | 130.184 |
| Halter Fitting | Gewinde Thread   |                |                |         |         |         |
| 130.145        | 1/4" AG  |                |                |         |         |         |
| 130.184        | 1/4" AG  |                |                |         |         |         |
|                |  |                |                |         |         |         |
| 20mm           | 40.0g  |                |                |         |         |         |

| 213.070.800._  |   |                |                |  |
|----------------|---|----------------|----------------|--|
|                | <b>Materialcode</b><br>05 Polyurethan<br>20 TPU   |                |                |  |
|                | <table border="1"> <thead> <tr> <th>Halter Fitting</th> <th>Gewinde Thread</th> </tr> </thead> <tbody> <tr> <td></td> <td></td> </tr> </tbody> </table> | Halter Fitting | Gewinde Thread |  |
| Halter Fitting | Gewinde Thread  |                |                |  |
|                |   |                |                |  |
|                |   |                |                |  |
| 18mm           | 61.5g   |                |                |  |



223.070.800.\_

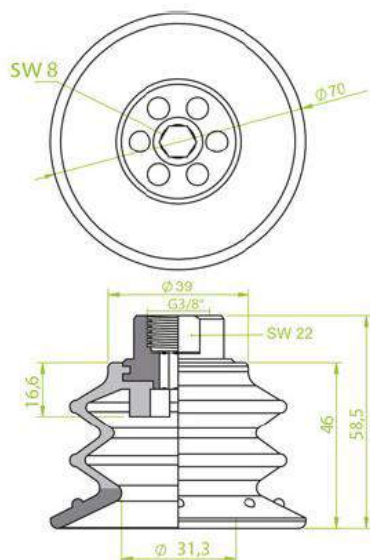

Materialcode

20 TPU

Halter  
Fitting

Gewinde  
Thread



23mm



66.5g

224.070.800.\_

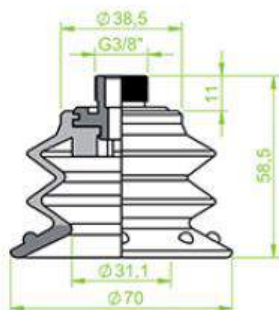
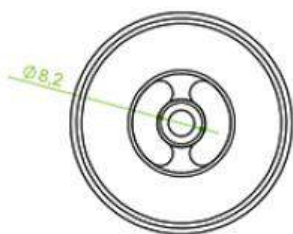

Materialcode

20 TPU

Halter  
Fitting

Gewinde  
Thread



23mm



60.4g

210.075.033.\_

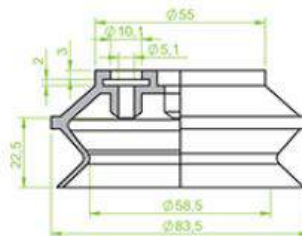
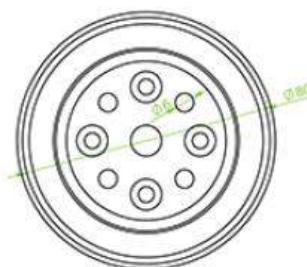

Materialcode

05 Polyurethan  
02 Silikon

Halter  
Fitting

Gewinde  
Thread

130.138

1/8" IG



22mm



45.0g



211.075.006.\_

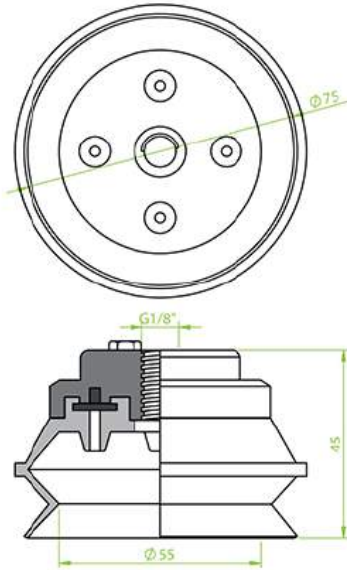

Materialcode

05 Polyurethan  
02 Silikon

Halter  
Fitting

Gewinde  
Thread



22mm

113.0g

213.075.038.\_

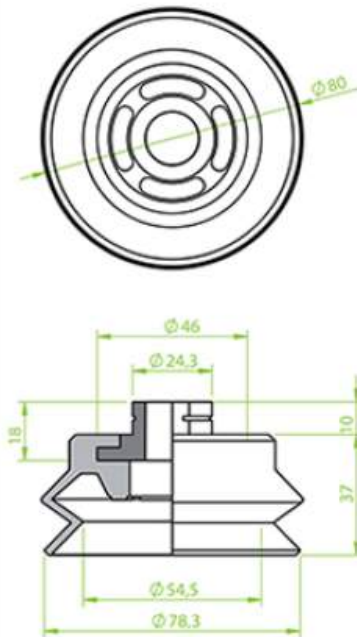

Materialcode

01 NBR

Halter  
Fitting

Gewinde  
Thread



mm

0.0g



210.078.131.\_

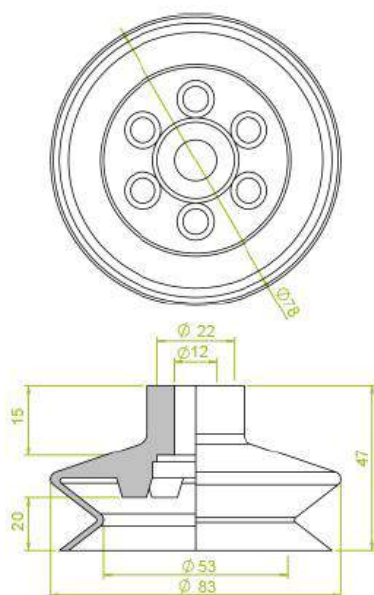

Materialcode

02 Silikon

Halter  
Fitting

Gewinde  
Thread

130.184

1/4" AG

130.622

1/4" AG

130.623

1/4" IG



14mm

55.0g

213.078.007.\_

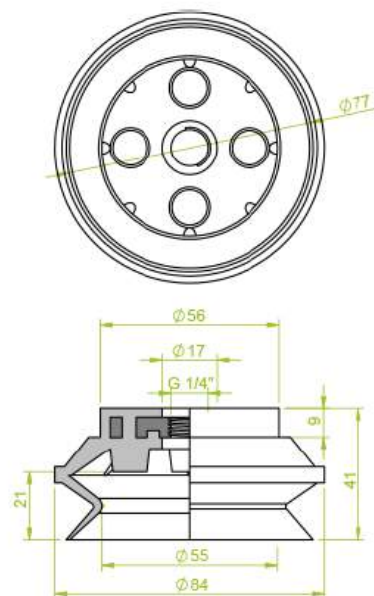

Materialcode

05 Polyurethan  
02 Silikon

Halter  
Fitting

Gewinde  
Thread



21mm

73.0g



|                      |                       |                       |
|----------------------|-----------------------|-----------------------|
| <b>215.080.003._</b> |                       |                       |
|                      | <b>Materialcode</b>   |                       |
|                      | 09 HNBR               |                       |
|                      | <b>Halter Fitting</b> | <b>Gewinde Thread</b> |
|                      |                       |                       |
|                      |                       |                       |
| 23mm                 | 64.0g                 |                       |

|                      |                       |                       |
|----------------------|-----------------------|-----------------------|
| <b>210.082.133._</b> |                       |                       |
|                      | <b>Materialcode</b>   |                       |
|                      | 02 Silikon            |                       |
|                      | <b>Halter Fitting</b> | <b>Gewinde Thread</b> |
|                      | 130.327               | 1/4" AG               |
|                      |                       |                       |
| mm                   | 0.0g                  |                       |







| 214.085.002._         |                        |
|-----------------------|------------------------|
|                       | <b>Materialcode</b>    |
|                       | 12 verstärktes Silikon |
| <b>Halter Fitting</b> | <b>Gewinde Thread</b>  |
|                       |                        |
| mm                    | 0.0g                   |

| 223.085.007._         |   |
|-----------------------|---|
|                       | <b>Materialcode</b>                           |
|                       | 03 NR<br>02 Silikon<br>12 verstärktes Silikon |
| <b>Halter Fitting</b> | <b>Gewinde Thread</b>                         |
|                       |   |
| 33mm                  | 190.0g  |

| 224.085.001._         |                        |
|-----------------------|------------------------|
|                       | <b>Materialcode</b>    |
|                       | 12 verstärktes Silikon |
| <b>Halter Fitting</b> | <b>Gewinde Thread</b>  |
|                       |                        |
| 38mm                  | 209.0g                 |